



Department  
of Health

# Next Steps for Becoming Compliant with CMS Conflict of Interest Requirements

August 9, 2019

# Compliant Conflict of Interest (COI) Models

- Over the past three stakeholder meetings (January 11, 2019; March 6, 2019; and May 14, 2019 - including CMS participation) together we have explored and vetted potential models and options for becoming compliant with CMS Conflict of Interest Rules (COI) under the NHTD and TBI Waivers.
- From those discussions, the following models have been identified, and verified by CMS, as COI compliant:
  - Provider offers Service Coordination (SC) only
  - Provider offers Waiver Services\* only
  - Provider offers SC and Waiver Services\*, but cannot provide both Service Coordination AND Waiver services\* to *the same participant*

*\*NHTD and TBI Waivers Services that are subject to COI requirements*

NHTD Waiver Services			TBI Waiver Services		
<i>Exempt from COI Services</i>	<i>Services Subject to COI</i>		<i>Exempt from COI Services</i>	<i>Services Subject to COI</i>	
Assistive Technology (AT)	Service Coordination	Independent Living Skills and Training	Assistive Technology (AT)	Service Coordination	Independent Living Skills and Training (ILST)
Moving Assistance (MA)	Community Integration Counselling (CIC)	Structured Day Program Services	Community Transitional Services (CTS)	Structured Day Program Services	Positive Behavioral Interventions and Support Services (PBIS)
Community Transitional Services (CTS)	Nutritional Counseling/Educational Services	Transportation Services	Environmental Modifications (E-Mods)	Substance Abuse Program Services	
Congregate and Home Delivered Meals (Meals)	Peer Mentoring	Wellness Counselling		Transportation Services	
Environmental Modifications (E-Mods)	Positive Behavioral Interventions and Support Services (PBIS)	Home and Community Support Services (HCSS)		Community Integration Counselling (CIC)	
	Respiratory Therapy	Home Visits by Medical Personnel		Home and Community Support Services (HCSS)	
	Respite			Respite	

August 9, 2019

COI Compliant Models - Provider Offers Both SC and Waiver Services\* but **NOT** to the Same Individual

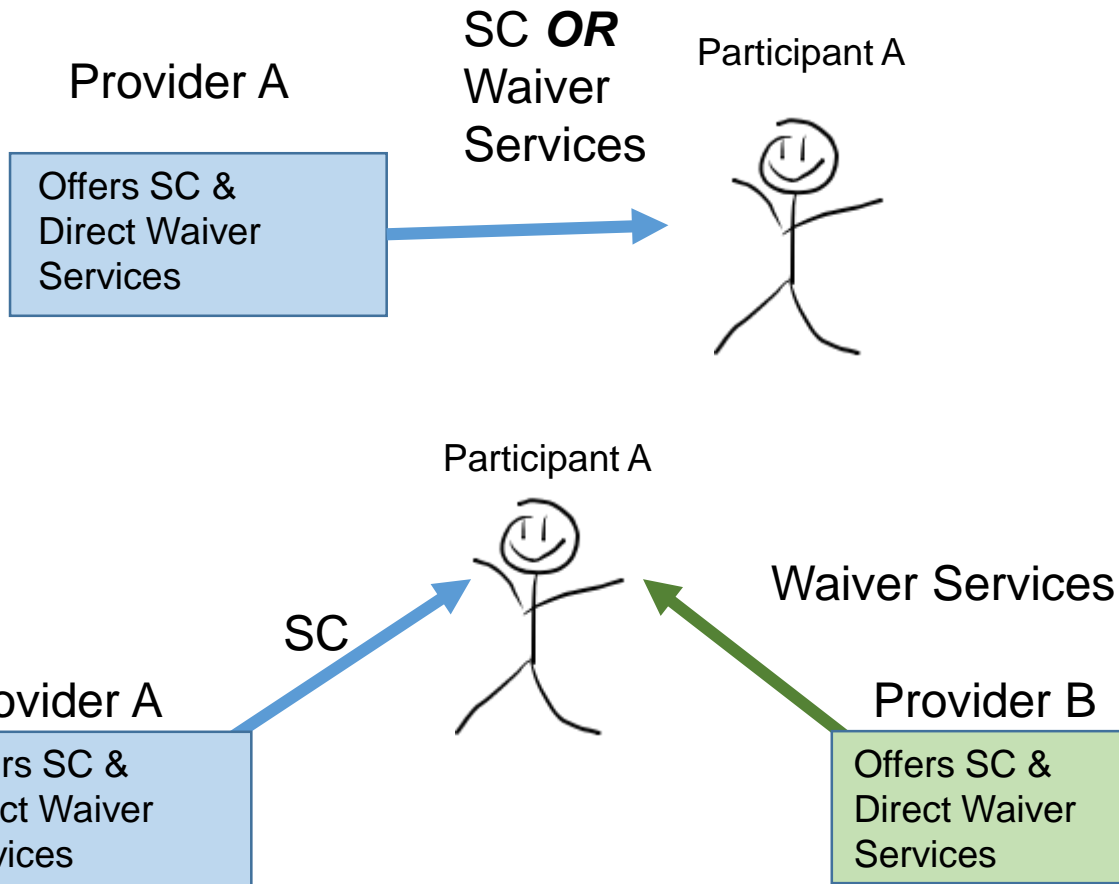

COI "Naturally" Compliant Models Provider Offers Only SC or Waiver Services but NOT Both

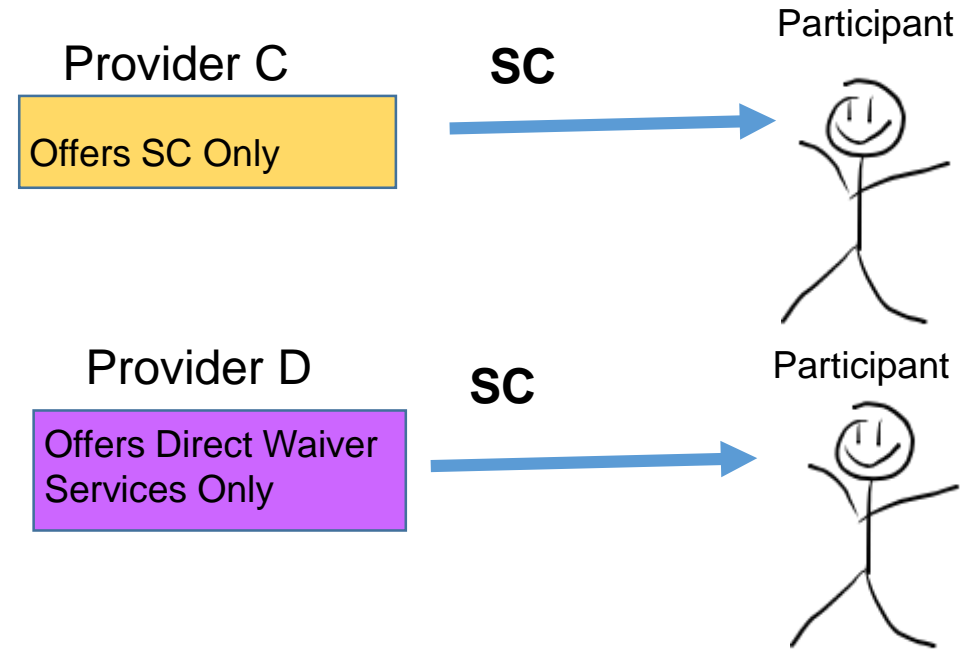

\*Exempt Waiver services (Emods, Vmods, AT, CTS, MA and Meals) are not subject to COI and do not factor into whether a provider is COI compliant

# Next Steps to Transition to COI Compliance

- DOH and providers/stakeholders work collaboratively to transition to COI compliant models by January 1, 2021 – key goal ensuring access to all waiver services.
- Moving to compliance can be an opportunity for providers, some time should be taken to assess landscape.
- To help both providers and DOH assess the current landscape of service provision, DOH is compiling a year of claims data (for April 2018 to March 2019), by provider, and county, for service coordination, exempt and non-exempt Waiver services. Data will also include the number of unique members receiving each group of services.
- Data will provide insight into:
  - Who is COI compliant today, and who is not;
  - Whether there are currently rural/cultural exemptions from COI (only willing provider);
  - Help providers think about their options for compliance; and
  - Help DOH work with providers to assess and address potential transition issues.

# Data by Provider – Example Provider ABC

	MEMBERS RECEIVE SERVICE COORDINATION ONLY FROM PROVIDER ABC			MEMBERS RECEIVE ONLY WAIVER SERVICES SUBJECT TO COI FROM PROVIDER ABC			MEMBERS THAT RECEIVE WAIVER SERVICES EXEMPT FROM COI			NON EXEMPT WAIVER SERVICES AND SERVICE COORDINATION TO SAME MEMBER			
	REVENUE	% OF TOTAL COUNTY REVENUE	Unique Recipients	REVENUE	% OF TOTAL COUNTY REVENUE	Unique Recipients	REVENUE	% OF PROVIDER'S TOTAL COUNTY REVENUE	Unique Recipients	REVENUE	% OF PROVIDER'S TOTAL COUNTY REVENUE	Unique Recipients	TOTAL
PROVIDER ABC County	A	A/E		B	B/E		C	C/E		D	D/E		E
BROOME	\$39,392	95%	15	\$2,269	5%	2	\$0	0%		\$0	0%	0	\$41,661
CAYUGA	\$27,968	76%	7	\$8,645	24%	6	\$0	0%		\$0	0%	0	\$36,613
CHEMUNG	\$4,727	12%	1	\$5,439	14%	1	\$14,542	37%	1	\$14,542	37%	1	\$39,251
CHENANGO	\$9,454	100%	3	\$0	0%	0	\$0	0%		\$0	0%	0	\$9,454
CORTLAND	\$3,151	24%	1	\$0	0%	0	\$0	0%		\$9,914	76%	1	\$13,065
HERKIMER	\$7,091	86%	2	\$1,189	14%	1	\$0	0%		\$0	0%	0	\$8,279
JEFFERSON	\$22,847	100%	6	\$0	0%	0	\$0	0%		\$0	0%	0	\$22,847
MADISON	\$4,727	19%	1	\$1,009	4%	1	\$0	0%		\$19,015	77%	2	\$24,751
ONEIDA	\$0	0%	0	\$0	0%	0	\$17,692	33%	2	\$35,383	67%	4	\$53,075
ONONDAGA	\$187,900	36%	49	\$39,856	8%	13	\$85,084	16%	10	\$204,202	39%	24	\$517,042
OSWEGO	\$19,696	46%	5	\$2,971	7%	4	\$0	0%		\$20,613	48%	3	\$43,280
SCHUYLER	\$0	0%	0	\$2,629	100%	1	\$0	0%		\$0	0%	0	\$2,629
STEUBEN	\$11,424	23%	3	\$20,026	40%	6	\$0	0%		\$18,567	37%	2	\$50,017
TIOGA	\$3,151	100%	1	\$0	0%	0	\$0	0%		\$0	0%	0	\$3,151
TOMPKINS	\$4,333	25%	1	\$8,429	48%	1	\$0	0%		\$4,871	28%	1	\$17,633
<b>TOTAL</b>	<b>\$345,862</b>	<b>39%</b>	<b>95</b>	<b>\$92,462</b>	<b>10%</b>	<b>36</b>	<b>\$117,318</b>	<b>13%</b>	<b>13</b>	<b>\$327,108</b>	<b>37%</b>	<b>38</b>	<b>\$882,749</b>
													<b>GRAND TOTAL</b>

August 9, 2019



Department of Health

# Data By County and Provider

County x	MEMBERS RECEIVE SERVICE COORDINATION ONLY FROM PROVIDER ABC			MEMBERS RECEIVE ONLY WAIVER SERVICES SUBJECT TO COI FROM PROVIDER ABC			MEMBERS THAT RECEIVE WAIVER SERVICES EXEMPT FROM COI			NON EXEMPT WAIVER SERVICES AND SERVICE COORDINATION TO SAME MEMBER			TOTAL
	% OF PROVIDER'S REVENUE TOTAL REVENUE			% OF PROVIDER'S REVENUE TOTAL REVENUE			% OF PROVIDER'S REVENUE TOTAL REVENUE			% OF PROVIDER'S REVENUE TOTAL REVENUE			
	A	A/E	Unique Recipients	B	B/E	Unique Recipients	C	C/E	Unique Recipients	D	D/E	Unique Recipients	
Provider 1	\$31,711	1%	9	\$327,417	15%	8	\$503,349	24%	4	\$1,258,373	59%	10	\$2,120,850
Provider 2	\$21,666	15%	5	\$89,585	60%	38	\$0	0%	0	\$37,930	25%	7	\$149,181
Provider 3	\$345,862	39%	95	\$92,462	10%	36	\$87,142	10%	10	\$357,283	40%	41	\$882,749
Provider 4	\$39,432	7%	8	\$40,884	7%	2	\$0	0%	0	\$510,312	86%	20	\$590,628
Provider 5	\$0	0%	0	\$111,361	100%	8	\$0	0%	0	\$0	0%	0	\$111,361
Provider 6	\$18,514	100%	4	\$0	0%	0	\$0	0%	0	\$0	0%	0	\$18,514
Provider 7	\$84,498	100%	16	\$0	0%	0	\$0	0%	0	\$0	0%	0	\$84,498
				\$2,280,87									
Provider 8	\$0	0%	0	4	99%	29	\$0	0%	0	\$26,681	1%	1	\$2,307,555
Provider 9	\$0	0%	0	\$33,499	100%	5	\$0	0%	0	\$0	0%	0	\$33,499
Provider 10	\$38,998	6%	11	\$272,501	39%	15	\$78,694	11%	3	\$314,777	45%	12	\$704,970
Provider 11	\$44,119	58%	12	\$14,336	19%	4	\$0	0%	0	\$17,288	23%	3	\$75,743
Provider 12	\$25,606	4%	6	\$124,630	19%	24	\$0	0%	0	\$490,521	77%	26	\$640,756
Provider 13	\$17,726	0%	4	\$863,735	19%	13	\$0	0%	0	\$3,680,668	81%	31	\$4,562,129
				\$2,040,09									
Provider 14	\$0	0%	0	6	100%	30	\$0	0%	0	\$0	0%	0	\$2,040,096
<b>TOTAL</b>	<b>\$668,132</b>	<b>5%</b>	<b>170</b>	<b>\$6,291,37</b>	<b>44%</b>	<b>212</b>	<b>\$669,186</b>	<b>5%</b>	<b>17</b>	<b>\$6,693,834</b>	<b>47%</b>	<b>151</b>	<b>\$14,322,529</b>
													<b>GRAND TOTAL</b>

August 9, 2019

# Next Steps to Transition to COI Compliance

- DOH will provide data, like the example for Provider ABC, to each provider for each waiver program.
- DOH expects to have all the data compiled and out to individual providers by the first week of September.
- Upon distribution of data to providers, DOH will request that within 30 days, providers share with DOH their initial thoughts on any changes to their current service provisioning they may make to become COI compliant.
- DOH will use that information to:
  - Summarize data across the State;
  - Look at how landscape changes across State;
  - Identify members that may need to transition;
  - Identify potential service gaps/opportunities; and
  - Identify rural/cultural exemptions.

August 9, 2019



# Other Options to Facilitate Smooth Transition to COI Compliance

- At our prior meetings we have also discussed exploring programmatic options that can help ease the transition to full COI compliance:
  - ✓ Continue efforts to expand the number of Service Coordination providers
  - ✓ Staff Qualifications

## Other Actions to Help Facilitate Smooth Transition to COI Compliance

- In 2017 and 2018 provider qualifications for TBI and NHTD were changed and are reflected in the current waivers.
- Providers and stakeholders have indicated the qualifications for professional staff in the current waiver applications are challenging.
- This has impeded hiring new staff and may make transition to COI even more challenging.
- As part of the transition plan to COI compliance, an option could be to seek the approval of CMS to amend the current application to adjust staff qualifications while ensuring capable and qualified staff are providing services under both waivers.

# Staff Qualifications

- Grandfather existing staff (have demonstrated experience).
- Staff currently providing services would be grandfathered at their current qualifications and be allowed to transfer to new employers under those grandfathered qualifications (this includes those now under the 2010 qualifications).
- Amend staff qualifications for Independent Living Skills Training Services (ILST), Community Integration Counseling Services (CIC), Positive Behavioral Interventions and Support Services (PBIS), Service Coordination (SC) and Program Director for Structured Day Program Services (SDP).
- Proposal to amend staff qualifications – standards exceed 2010 standards but provide more flexibility than today's standards and recognize the supply.
- The following slides provide a proposal for adjusting qualifications for review and discussion.

## NHTD SC: 2010 Qualifications

(A) The following staff may provide Service Coordination without supervision:

1. Licensed Master Social Worker (licensed by the NYS Education Department);
2. Licensed Clinical Social Worker (licensed by the NYS Education Department);
3. Master of Social Work;
4. Master of Psychology;
5. Master of Counseling Psychology;
6. Master of School Psychology;
7. Master of Counseling;
8. Master of Gerontology;
9. Physical Therapist (licensed by the NYS Education Department);
10. Registered Professional Nurse (licensed by the NYS Education Department);
11. Certified Special Education Teacher (certified as a Special Education Teacher by the NYS Education Department);
12. Certified Rehabilitation Counselor (certified by the Commission on Rehabilitation Counselor Certification);
13. Licensed Speech Pathologist (licensed by the NYS Education Department); or
14. Occupational Therapist (licensed by the NYS Education Department).

Providers in Group (A) shall have, at a minimum:

1. One (1) year of experience providing Service Coordination and information, linkages and referrals regarding community based services for individuals with disabilities and/or seniors; OR
2. Have a Bachelor's degree, or higher, in social work, psychology, gerontology, or other related field and two (2) years of experience providing Service Coordination to individuals with disabilities and/or seniors and knowledge about community resources; OR
3. Be an individual who has successfully served as a Regional Resource Development Specialist for one (1) year.
4. Any individual who met the qualifications for and was providing Service Coordination without supervision under the NHTD waiver in effect through August 31, 2010.

## NHTD SC: 2018 Qualifications

Persons employed as Service Coordinators must be a/an:

- Licensed Master Social Worker (Licensed by the NYS Education Department);
- Licensed Clinical Social Worker (Licensed by the NYS Education Department);
- Individual with a Doctorate or Master of Social Work;
- Individual with a Doctorate or Master of Psychology;
- Individual with a Master of Gerontology;
- Licensed Physical Therapist (Licensed by the NYS Education Department);
- Registered Professional Nurse (Licensed by the NYS Education Department);
- Certified Teacher of Students with Disabilities (Certified by the NYS Education Department);
- Certified Rehabilitation Counselor (Certified by the Commission of Rehabilitation Counselor Certification);
- Licensed Speech Pathologist (Licensed by the NYS Education Department); OR
- Licensed Occupational Therapist (Licensed by the NYS Education Department);

AND

Must have, at a minimum, one (1) year of experience providing case management/service coordination and information, linkages and referrals regarding community-based services for individuals with disabilities and/or seniors;

OR

Individual with a Bachelor's degree and three (3) years of experience providing case management/service coordination, information, linkages and referrals regarding community-based services for individuals with disabilities and/or seniors.

## NHTD SC: For Discussion

Include:

OR

- An individual with an Associates degree and 5 years experience providing case management/service coordination, information, linkages and referrals regarding community-based services for individuals with disabilities and/or seniors.

## NHTD CIC: 2010 Qualifications

## NHTD CIC: 2018 Qualifications

## NHTD CIC: For Discussion

(A) The following staff may provide Community Integration Counseling services without supervision:

1. Licensed Psychologist (licensed by the NYS Education);
2. Licensed Master Social Worker (licensed by the NYS Education Department);
3. Licensed Clinical Social Worker (licensed by the NYS Education Department);
4. Master of Social Work;
5. Master of Psychology;
6. Master of Counseling Psychology;
7. Master of School Psychology;
8. Master of Counseling;
9. Mental Health Practitioner (licensed by NYS Education Department);
10. Certified Rehabilitation Counselor (certified by the Commission on Rehabilitation Counselor Certification);
11. Certified Special Education Teacher (Certified by the NYS Education Department).

Providers in Group (A) must have, at a minimum, two (2) years of experience providing adjustment related counseling to individuals and/or seniors with physical and/or cognitive disabilities and their families.

Persons employed as a Community Integration Counselor must be a/an:

1. Licensed Psychiatrist (Licensed by the NYS Education Department);
2. Licensed Psychologist (Licensed by the NYS Education Department);
3. Licensed Master Social Worker (Licensed by the NYS Education Department);
4. Licensed Clinical Social Worker (Licensed by the NYS Education Department);
5. Individual with a Doctorate degree in Psychology;
6. Licensed Mental Health Practitioner (Licensed by the NYS Education Department) (This includes Creative Arts Therapists, Marriage and Family Therapists, Mental Health Counselors, and Psychoanalysts); or
7. Certified Rehabilitation Counselor (Certified by the Commission on Rehabilitation Counselor Certification);

AND

Must have, at a minimum, two (2) years of experience providing adjustment related counseling to seniors and/or individuals with physical and/or cognitive disabilities and their families to be considered qualifying experience.

**Include:**

8. Master of Social Work
9. Master of Psychology
10. Certified Teacher of Students with Disabilities (certified by the NYS Education Department)
11. Master of Gerontology

(And two (2) years of experience providing adjustment related counseling to seniors and/or individuals with physical and/or cognitive disabilities and their families to be considered qualifying experience.)

# NHTD PBIS: 2010 Qualifications

The providers must employ a Program Director who is a:

(A) Licensed psychiatrist (licensed by the NYS Education Department) with one year experience providing behavioral services; OR

(B) Licensed psychologist (licensed by the NYS Education Department) with one year experience in providing behavioral services; Or

(C) Licensed Master Social Worker (licensed by the NYS Education Department);

- Licensed Clinical Social Worker (licensed by the NYS Education Department);
- Master of Social Work,
- Master of Psychology,
- Master of Gerontology,
- Physical Therapist (licensed by the NYS Education Department),
- Mental Health Practitioner (licensed by NYS Education Department),
- Registered Professional Nurse (registered by the NYS Education Department)
- Certified Special Education Teacher (certified by the NYS Education Department),
- Certified Rehabilitation Counselor (certified by the Commission on Rehabilitation Counselor Certification),
- Licensed Speech Language Pathologist (licensed by the NYS Education Department); OR
- Occupational Therapist (licensed by the NYS Education Department).

Each of the individuals in (C) must have, at a minimum, two years of experience providing neurobehavioral services; OR

Behavioral Specialist with two (2) years of experience, one year of which must be with individuals and/or seniors with disabilities, or behavioral difficulties and be a:

A) Person with a Bachelor's degree; OR

B) Licensed Practical Nurse (licensed by the NYS Education Department pursuant to Article 139 of the NYS Education Law); OR

C) Certified Occupational Therapy Assistant (certified by the NYS Education Department); OR

D) Physical Therapy Assistant (certified by the NYS Education Department pursuant to Article 136 of the NYS Education Law).

The Behavioral Specialist must be supervised by the Program Director.

# NHTD PBIS: 2018 Qualifications

Persons employed as a PBIS Program Director must be a:

- Licensed psychiatrist (licensed by the NYS Education Department);
- Licensed psychologist (licensed by the NYS Education Department);
- Doctorate or Master Degree in Psychology;
- Licensed Master Social Worker (licensed by the NYS Education Department);
- Licensed Clinical Social Worker (licensed by the NYS Education Department);
- Master Level Certified Teacher of Students with Disabilities (Certified by the NYS Education Department); or
- Licensed Behavior Analyst (Licensed by the NYS Education Department).

AND

Must have two (2) years of experience developing and implementing intensive behavioral plans.

Persons employed as a Behavioral Specialist must be a/an:

- Individual with a Bachelor's degree in psychology;
- Registered Professional Nurse (Registered by the NYS Education Department);
- Licensed Occupational Therapist (Licensed by the NYS Education Department);
- Licensed Physical Therapist (Licensed by the NYS Education Department);
- Certified Behavior Analyst Assistant (Certified by the NYS Education Department);
- Individual with a Bachelor's degree and a Certified TBI Specialist;
- Certified Rehabilitation Counselor (Certified by the Commission on Rehabilitation Counselor Certification);

AND

Must have two (2) years of experience developing and implementing intensive behavioral treatment plans.

All agencies that employ two (2) or more Behavioral Specialists, regardless of credentials, must provide supervision by an individual who meets the criteria for PBIS Program Director.

# NHTD PBIS: For Discussion

Program Director:  
Include:

- Master of Social Work
- Master of Psychology
- Master of Gerontology

(And two (2) years of experience developing and implementing intensive behavioral plans.)

Behavioral Specialist:  
Include:

- Individual with a Bachelor's degree and certified in Applied Behavioral Analysis (ABA)
- Bachelor's and a Certified Dementia Practitioner
- Bachelor's and a CARES Dementia Specialist

(And two (2) years of experience developing and implementing intensive behavioral treatment plans.)

# NHTD ILST: 2010 Qualifications

(A) The following staff may provide Independent Living Skills Training services without supervision:

1. Licensed Master Social Worker (licensed by the NYS Education Department);
2. Licensed Clinical Social Worker (licensed by the NYS Education Department);
3. Master of Social Work;
4. Master of Psychology;
5. Physical Therapist (licensed by the NYS Education Department);
6. Registered Professional Nurse (registered by the NYS Education Department);
7. Certified Special Education Teacher (certified as a Special Education Teacher by the NYS Education Department);
8. Certified Rehabilitation Counselor (certified by the Commission on Rehabilitation Counselor Certification), Licensed Speech Pathologist (licensed by the NYS Education Department pursuant to Article 159 of the NYS Education Law); OR
9. Registered Occupational Therapist (registered by the NYS Education Department pursuant to Article 156 of the NYS Education Law).

Providers in Group A must have, at a minimum one (1) year of experience completing functionally based assessments, developing comprehensive treatment plans and teaching individuals with disabilities, and/or seniors to be more functionally independent; OR

1. An individual with a Bachelor's degree and two (2) years of experience completing functionally based assessments, developing comprehensive treatment plans and teaching individuals with disabilities, and/or seniors to be more functionally independent;
2. An individual with an Associate's degree with three (3) years of experience completing functionally based assessments, developing comprehensive treatment plans and teaching individuals with disabilities, and/or seniors to be more functionally independent; OR
3. An individual with a High School Diploma or equivalent and five (5) years of experience completing functionally based assessments, developing comprehensive treatment plans and teaching individuals with disabilities, and/or seniors to be more functionally independent.
4. Any individual who met the qualifications for and was providing Independent Living Skills Training without supervision under the NHTD waiver in effect through August 31, 2010.

# NHTD ILST: 2018 Qualifications

Persons employed as an Independent Living Skills and Training provider must be a/an:

1. Licensed Master Social Worker (licensed by the NYS Education Department);
2. Licensed Clinical Social Worker (licensed by the NYS Education Department);
3. Individual with a Doctorate or Master of Social Work;
4. Individual with a Doctorate or Master of Psychology;
5. Licensed Physical Therapist (licensed by the NYS Education Department);
6. Registered Professional Nurse (registered by the NYS Education Department);
7. Certified Teacher of Students with Disabilities (certified by the NYS Education Department);
8. Certified Rehabilitation Counselor (certified by the Commission on Rehabilitation Counselor Certification);
9. Licensed Speech Pathologist (licensed by the NYS Education Department); or
10. Registered Occupational Therapist (registered by the NYS Education Department);

AND  
Must have, at a minimum, one (1) year of experience completing functional based assessments of ADLs and IADLs, developing comprehensive treatment plans and teaching individuals with disabilities and/or seniors to be more functionally independent.

OR  
Be an individual with a Bachelor's degree and three (3) years of experience completing functional based assessments of ADLs and IADLs, developing comprehensive treatment plans and teaching individuals with disabilities and/or seniors to be more functionally independent;

OR  
Be an individual with an Associate's degree and five (5) years of experience completing functional based assessments of ADLs and IADLs, developing a comprehensive treatment plan, and teaching individuals with disabilities and/or seniors to be more functionally independent.

# NHTD ILST: 2020 For Discussion

Include:

11. Master of Social Work
12. Master of Psychology
13. Master of Gerontology

(And one (1) year of experience completing functional based assessments of ADLs and IADLs, developing comprehensive treatment plans and teaching individuals with disabilities and/or seniors to be more functionally independent.)

# NHTD SDP Program Director: 2010 Qualifications

(A)The Structure Day Program Director must be a:

1. Licensed Master Social Worker (licensed by the NYS Education Department);
2. Licensed Clinical Social Worker (licensed by the NYS Education Department);
3. Master of Social Work;
4. Master of Psychology;
5. Master of Counseling Psychology;
6. Master of School Psychology;
7. Master of Gerontology;
8. Physical Therapist (licensed by the NYS Education Department);
9. Registered Professional Nurse (licensed by the NYS Education Department);
10. Certified Special Education Teacher (certified as a Special Education Teacher by the NYS Education Department);
11. Certified Rehabilitation Counselor (certified as a Certified Rehabilitation Counselor (CRC) by the Commission on Rehabilitation Counselor Certification);
12. Licensed Speech Pathologist (licensed by the NYS Education Department); OR
13. Occupational Therapist (licensed by the NYS Education Department).

Individuals in Group (A) must have, at a minimum, one (1) year of experience providing functional assessments, Positive Behavioral Interventions and Supports or Structured Day Program services to individuals with disabilities, and/or seniors:

OR

(B) Be an individual with a Bachelor's degree or higher, in social work, psychology, gerontology, or other related field and two (2) years of experience providing functional assessments, Positive Behavioral Interventions and Supports or Structured Day Program services to individuals with disabilities, and/or seniors.

# NHTD SDP Program Director: 2018 Qualifications

Persons employed as a Structured Day Program Director must be a/an:

1. Licensed Master Social Worker (licensed by the NYS Education Department);
2. Licensed Clinical Social Worker (licensed by the NYS Education Department);
3. Individual with a Doctorate or Master of Social Work;
4. Individual with a Doctorate or Master of Psychology;
5. Licensed Physical Therapist (licensed by the NYS Education Department);
6. Registered Professional Nurse (licensed by the NYS Education Department);
7. Certified Teacher of Students with Disabilities (certified by the NYS Education Department);
8. Certified Rehabilitation Counselor (certified as a Certified Rehabilitation Counselor (CRC) by the Commission on Rehabilitation Counselor Certification);
9. Licensed Speech Pathologist (licensed by the NYS Education Department); or
10. Licensed Occupational Therapist (licensed by the NYS Education Department);

AND Must have one (1) year of experience developing and implementing day habilitation plans; providing vocational education services; providing residential habilitation services; or providing job coaching or supportive employment services.

OR

Individual with a Bachelor's degree and two (2) years of experience developing and implementing day habilitation plans; providing vocational education services; providing residential habilitation services; or providing job coaching or supportive employment services.

The SDP must be available to provide hands-on assistance to members, and therefore, must have at least one (1) employee with previous training as a PCA or CNA available to members at all times. In addition to a required Program Director and staff with PCA/CNA training, a SDP may employ additional program staff.

# NHTD SDP Program Director: For Discussion

Include:

## 11. Master of Gerontology

(And one (1) year of experience developing and implementing day habilitation plans; providing vocational education services; providing residential habilitation services; or providing job coaching or supportive employment services.)



# TBI SC: 2010 Qualifications

# TBI SC: 2017 Qualifications

# TBI SC: For Discussion

(A) - Master of Social Work,  
 - Doctorate or Master of Psychology,  
 - Registered Physical Therapist (licensed by the NYS Education Department pursuant to Article 136 of the NYS Education Law),  
 - Registered Professional Nurse (licensed by the NYS Education Department pursuant to Article 139 of the NYS Education Law),  
 - Certified Special Education Teacher (certified as a Special Education Teacher by the NYS Education Department),  
 - Certified Rehabilitation Counselor (certified as a Certified Rehabilitation Counselor (CRC) by the Commission on Rehabilitation Counselor Certification),  
 - Licensed Speech Pathologist (licensed by the NYS Education Department pursuant to Article 159 of the NYS Education Law); or  
 - Registered Occupational Therapist (licensed by the NYS Education Department pursuant to Article 156 of the NYS Education Law).

Providers in Group (A) shall have, at a minimum:  
 - one (1) year of experience providing Service Coordination and information, linkages and referral regarding community based services for individuals with disabilities; OR

B) An individual with a Bachelor's degree; and two (2) years' experience providing service coordination and information, linkages and referral regarding community based services for individuals with disabilities; OR

C) An individual with an Associate's degree; and three (3) years' experience providing service coordination to individuals with disabilities and information, linkages and referral regarding community based services for individuals with disabilities; OR

D) An individual with a high school diploma or equivalent (i.e. GED) with four (4) years' experience providing service coordination to individuals with disabilities and information, linkages and referral regarding community based services for individuals with disabilities; OR

E) An individual who has successfully served as a Regional Resource Development Specialist for a minimum of one (1) year in the TBI Waiver Program.

1. Licensed Master Social Worker (LMSW- licensed by the NYS Education Department);
  2. Licensed Clinical Social Worker (LCSW- licensed by the NYS Education Department);
  3. Individual with a Doctorate or Master of Social Work degree;
  4. Individual with a Doctorate or Master of Psychology degree;
  5. Licensed Physical Therapist (licensed by the NYS Education Department);
  6. Registered Professional Nurse (licensed by the NYS Education Department);
  7. Certified Teacher of Students with Disabilities (certified by the NYS Education Department);
  8. Certified Rehabilitation Counselor (certified as a Certified Rehabilitation Counselor (CRC) by the Commission on Rehabilitation Counselor Certification);
  9. Licensed Speech Pathologist (licensed by the NYS Education Department);
  10. Licensed Occupational Therapist (licensed by the NYS Education Department);
- AND Must have, at a minimum 1 year of experience providing case management/service coordination, information and referral services and service brokering of community based services for individuals with disabilities and/or Traumatic Brain Injury;
- OR
- Individual with a Bachelor's degree and 3 years of experience providing case management/service coordination, information and referral services and service brokering of community based services for individuals with disabilities and/or Traumatic Brain Injury.

Include:

OR

- An individual with an Associates degree and 5 years experience providing case management/service coordination, information and referral services and service brokering of community based services for individuals with disabilities and/or Traumatic Brain Injury.

## TBI CIC: 2010 Qualifications

-Licensed Psychiatrist (licensed by the NYS Education Department pursuant to Article 131 of the NYS Education Law);  
- Licensed Psychologist (licensed by the NYS Education Department pursuant to Article 153 of the NYS Education Law);  
- Master of Social Work;  
- Doctorate or Master of Psychology;  
- Mental Health Practitioner (licensed by NYS Education Department pursuant to Article 163 of the NYS Education Law);  
- Certified Rehabilitation Counselor (Certified as a Certified Rehabilitation Counselor (CRC) by the Commission on Rehabilitation Counselor Certification); or  
- Certified Special Education Teacher (Certified by the NYS Education Department).

Each of these individuals must have, at a minimum:  
-two (2) years of experience providing adjustment related counseling to individuals with traumatic brain injuries and their families.  
-A significant portion of the provider's time which represents this experience must have been spent providing counseling to individuals with traumatic brain injury and their families in order to be considered qualifying experience.

## TBI CIC: 2017 Qualifications

1. Licensed Psychiatrist (licensed by the NYS Education Department);
2. Licensed Psychologist (licensed by the NYS Education Department);
3. Licensed Master Social Worker (LMSW- licensed by the NYS Education Department);
4. Licensed Clinical Social Worker (LCSW- licensed by the NYS Education Department);
5. Individual with a Doctorate degree in Psychology;
6. Licensed Mental Health Practitioner (Licensed by NYS Education Department);
7. Certified Rehabilitation Counselor (Certified as a Certified Rehabilitation Counselor (CRC) by the Commission on Rehabilitation Counselor Certification);

AND  
Must have, at a minimum, 2 years of experience providing adjustment related counseling to individuals with Traumatic Brain Injuries and their families.

## TBI CIC: For Discussion

Include:

8. Master of Social Work
9. Master of Psychology
10. Certified Teacher of Students with Disabilities (certified by the NYS Education Department)

(And 2 years of experience providing adjustment related counseling to individuals with Traumatic Brain Injuries and their families.)

## TBI PBIS Program Director: 2010 Qualifications

The providers listed at the left must employ a Program Director who is a:

(A) Licensed psychiatrist (licensed by the NYS Education Department pursuant to Article 131 of the NYS Education Law) with one year experience providing behavioral services;

(B) Licensed psychologist (licensed by the NYS Education Department pursuant to Article 153 of the NYS Education Law) with one year experience in providing behavioral services or traumatic brain injury services;

(C) Master of Social Work,  
- Doctorate or Master degree in Psychology,  
- Registered Physical Therapist (licensed by the NYS Education Department pursuant to Article 136 of the NYS Education Law),  
- Mental Health Practitioner (licensed by NYS Education Department pursuant to Article 163 of the NYS Education Law),  
- Registered Professional Nurse (licensed by the NYS Education Department pursuant to Article 139 of the NYS Education Law),  
- Certified Special Education Teacher (certified as a Special Education Teacher by the NYS Education Department),  
- Certified Rehabilitation Counselor (certified as a Certified Rehabilitation Counselor (CRC) by the Commission on Rehabilitation Counselor Certification),  
- Licensed Speech Language Pathologist (licensed by the NYS Education Department pursuant to Article 159 of the NYS Education Law); or  
- Registered Occupational Therapist (licensed by the NYS Education Department pursuant to Article 156 of the NYS Education Law).  
Each of the individuals in (C) must have, at a minimum, two years of experience providing neurobehavioral services;

(D) An individual who has been a Behavioral Specialist for two (2) years and has successfully completed an apprenticeship program offered by the Statewide Neurobehavioral Resource Project.

## TBI PBIS Program Director: 2017 Qualifications

Persons employed as a PBIS Program Director or an Independent Provider must be a:

1. Licensed psychiatrist (licensed by the NYS Education Department);
2. Licensed psychologist (licensed by the NYS Education Department);
3. Doctorate or Master Degree in Psychology;
4. Licensed Clinical Social Worker (LCSW- licensed by the NYS Education Department);
5. Licensed Master Social Worker (LMSW- licensed by the NYS Education Department);
6. Certified Master's level Special Education Teacher (certified as a Special Education Teacher by the NYS Education Department); or
7. Licensed Behavior Analyst (Licensed by the NYS Education Department).

AND  
Must have 2 years of experience developing and implementing intensive behavioral plans.

## TBI PBIS Program Director: For Discussion

Include:

**8. Master of Social Work**

(And 2 years of experience developing and implementing intensive behavioral plans.)

Changing language for “Certified Master’s level Special Education Teacher” to:

- Certified Teacher of Students with Disabilities (certified by the NYS Education Department)

# TBI PBIS Behavioral Specialist: 2010 Qualifications

A Behavioral Specialist must be a:

- (A) Person with a Bachelor's degree;
- (B) Registered Professional Nurse (licensed by the NYS Education Department pursuant to Article 139 of the NYS Education Law);
- (C) Certified Occupational Therapy Assistant (certified by the NYS Education Department pursuant to Article 156 of the NYS Education Law); or
- (D) Physical Therapy Assistant (certified by the NYS Education Department pursuant to Article 136 of the NYS Education Law).

•Behavioral Specialists must have at least one (1) year of experience working with individuals with traumatic brain injury, other disabilities or behavioral difficulties.

•The Behavioral Specialist must successfully complete training in behavioral analysis and crisis intervention techniques which is provided by the Positive Behavioral Interventions and Supports program.

The Behavioral Specialist must be supervised by the Program Director. Supervision must occur no less than biweekly to review the caseload and must be more frequent when there is a new waiver participant, new provider or when significant behavioral issues arise.

# TBI PBIS Behavioral Specialist: 2017 Qualifications

Persons employed as a Behavioral Specialist must be a/an:

1. Individual with a Bachelor's degree in psychology;
2. Registered Professional Nurse (licensed by the NYS Education Department);
3. Licensed Occupational Therapist (licensed by the NYS Education Department);
4. Licensed Physical Therapist (licensed by the NYS Education Department);
5. Certified Behavior Analyst Assistant (Certified by the NYS Education Department);
6. Individual with a Bachelor's degree and a Certified TBI Specialist; or
7. A Certified Rehabilitation Counselor (certified by the Commission on Rehabilitation Counselor Certification);

AND

Must have 2 years of experience developing and implementing intensive behavioral plans.

\*All agencies that employ 2 or more Behavioral Specialists, regardless of credentials, must provide supervision by an individual who meets the criteria for PBIS Program Director.

# TBI PBIS Behavioral Specialist: For Discussion

Open for comment

# TBI ILST: 2010 Qualifications

# TBI ILST: 2017 Qualifications

# TBI ILST: For Discussion

Persons employed as an Independent Living Skills and Training provider must be a:

(A) - Master of Social Work,  
- Doctorate or Master of Psychology,  
- Registered Physical Therapist (licensed by the NYS Education Department pursuant to Article 136 of the NYS Education Law),  
- Registered Professional Nurse (licensed by the NYS Education Department pursuant to Article 139 of the NYS Education Law),  
- Certified Special Education Teacher (certified as a Special Education Teacher by the NYS Education Department),  
- Certified Rehabilitation Counselor (certified as a Certified Rehabilitation Counselor (CRC) by the Commission on Rehabilitation Counselor Certification),  
- Licensed Speech Pathologist (licensed by the NYS Education Department pursuant to Article 159 of the NYS Education Law), or  
- Registered Occupational Therapist (licensed by the NYS Education Department pursuant to Article 156 of the NYS Education Law).

Providers in Group A must have, at a minimum one (1) year of experience completing functionally based assessments, developing a comprehensive treatment plan and teaching individuals with disabilities to be more functionally independent; OR

(B) An individual with a Bachelor's Degree and two (2) years' experience completing functionally based assessments, developing a comprehensive treatment plan and teaching individuals with disabilities to be more functionally independent; OR

(C) An individual with an Associate's Degree and three (3) years' experience completing functionally based assessments, developing a comprehensive treatment plan and teaching individuals with disabilities to be more functionally independent; OR

(D) An individual with a High School Diploma or equivalent (i.e. GED) with four (4) years' experience completing functionally based assessments, developing a comprehensive treatment plan and teaching individuals with disabilities to be more functionally independent.

1. Licensed Clinical Social Worker (LCSW-licensed by the NYS Education Department);
  2. Licensed Master Social Worker (LMSW-licensed by the NYS Education Department);
  3. Individual with a Doctorate or Master of Social Work degree;
  4. Individual with a Doctorate or Master of Psychology degree;
  5. Licensed Physical Therapist (licensed by the NYS Education Department);
  6. Registered Professional Nurse (licensed by the NYS Education Department);
  7. Certified Teacher of Students with Disabilities (certified by the NYS Education Department);
  8. Certified Rehabilitation Counselor (certified as a Certified Rehabilitation Counselor (CRC) by the Commission on Rehabilitation Counselor Certification);
  9. Licensed Speech Pathologist (licensed by the NYS Education Department); or
  10. Licensed Occupational Therapist (licensed by the NYS Education Department);
- AND
- must have, at a minimum 1 year of experience completing assessments of ADLs/IADLs, developing comprehensive service plans, teaching individuals with Traumatic Brain Injury to be more functionally independent.
- OR
- Be an individual with a Bachelor's degree and 3 years of experience completing assessments of ADLs and IADLs, developing comprehensive service plans and teaching individuals with Traumatic Brain Injury to be more functionally independent;
- OR
- Be an individual with an Associate's degree and 5 years of experience completing assessments of ADLs and IADLs, developing a comprehensive service plan, teaching individuals with Traumatic Brain Injury to be more functionally independent.

Open for comment

## TBI SDP Program Director: 2010 Qualifications

Structured Day Program Director who is a:

- (A) - Master of Social Work,
- Doctorate or Master of Psychology,
- Registered Physical Therapist (licensed by the NYS Education Department pursuant to Article 136 of the NYS Education Law),
- Registered Professional Nurse (licensed by the NYS Education Department pursuant to Article 139 of the NYS Education Law),
- Certified Special Education Teacher (certified as a Special Education Teacher by the NYS Education Department),
- Certified Rehabilitation Counselor (certified as a Certified Rehabilitation Counselor (CRC) by the Commission on Rehabilitation Counselor Certification),
- Licensed Speech Language Pathologist (licensed by the NYS Education Department pursuant to Article 159 of the NYS Education Law), or
- Registered Occupational Therapist (licensed by the NYS Education Department pursuant to Article 156 of the NYS Education Law).

Individuals in Group (A) must have, at a minimum, one (1) year of experience providing functional assessments, Positive Behavioral Interventions and Support Services, or Structured Day Program services to individuals with disabilities: OR

(B) be an individual with a Bachelor's degree and two (2) years of experience providing functional assessments, Positive Behavioral Interventions and Support Services or Structured Day Program services to individuals with disabilities.

## TBI SDP Program Director: 2018 Qualifications

Persons employed as a Structured Day Program Director must be a/an:

1. Licensed Master Social Worker (LMSW- licensed by the NYS Education Department);
2. Licensed Clinical Social Worker (LCSW- licensed by the NYS Education Department);
3. Individual with a Doctorate or Master of Social Work degree;
4. Individual with a Doctorate or Master of Psychology degree;
5. Licensed Physical Therapist (licensed by the NYS Education Department);
6. Registered Professional Nurse (licensed by the NYS Education Department);
7. Certified Teacher of Students with Disabilities (certified NYS Education Department);
8. Certified Rehabilitation Counselor (certified as a Certified Rehabilitation Counselor (CRC) by the Commission on Rehabilitation Counselor Certification);
9. Licensed Speech Language Pathologist (licensed by the NYS Education Department); or
10. Licensed Occupational Therapist (licensed by the NYS Education Department);

AND  
Must have 1 year of experience developing and implementing day habilitation plans; providing vocational education services; providing residential habilitation services; or providing job coaching or supportive employment services.

OR  
Individual with a Bachelor's degree and 2 years of experience developing and implementing day habilitation plans; providing vocational education services; providing residential habilitation services; or providing job coaching or supportive employment services.

The SDP must be available to provide hands-on assistance to members, and therefore, must have at least 1 employee with previous training as a PCA or CNA available to members at all times. In addition to a required Program Director and staff with PCA/CNA training, a SDP may employ additional program staff.

## TBI SDP Program Director: For Discussion

Include:

11. Master of Gerontology

(And one (1) year of experience developing and implementing day habilitation plans; providing vocational education services; providing residential habilitation services; or providing job coaching or supportive employment services.)

# Formal Next Steps

- With general agreement on proposed qualifications:
  - The above qualifications will be posted on the MRT#90 website for further review and consideration.
  - After posting, NYSDOH will provide for a 30 day comment period.
  - After review of comments the final qualifications will be posted.
  - After closure of comments, the amendment will proceed for submission to CMS.

***Please send all comments to our mailbox below:***  
[waivertransition@health.ny.gov](mailto:waivertransition@health.ny.gov)